

19ft Scissor Lift

PERFORMANCE*

Platform Height–Elevated	5.8 m
Platform Capacity	230 kg
Capacity on Platform Extension	120 kg
Lift/Lower Time	25/26 seconds
Maximum Drive Height	Fully Elevated
Weight*	1,590 kg
Drive Speed–Elevated	0.8 km/h
Drive Speed–Lowered	3.2 km/h
Gradeability	25%
Turning Radius (Inside)	Zero
Turning Radius (Outside)	1.60 m

* Certain options or country standards will increase weight.

STANDARD FEATURES*

Power Source

Batteries	4 x 6V 220 amp-hr
Charger	20 amp (Universal Algorithm)
Drive	Hydraulic Front-wheel

Hydraulic Reservoir

- Capacity 17 L
- Pump Fixed Displacement Gear

Tires

- Tire Size/Type (Non-Marking) 323 x 100 mm

Brakes

- Multi-Disc Friction

STANDARD SPECIFICATIONS*

- Proportional Controls
- Battery Condition Indicator
- All Motion Alarm
- 20 Amp Automatic SCR Charger
- Horn
- Hourmeter
- Tilt Alarm and Light
- Lanyard Attach Points
- Movable, Removable Platform Control
- Nickel Plated Pins
- Lubrication Free Scissor Arm Bushings
- Scissor Maintenance Prop
- Active Pothole Protection System
- Lifting and Tie Down Points
- Fork Lift Pockets
- 86 cm Foot-Actuated
- Deck Extension
- Steel Swing-Out Doors
- Variable Tilt Window
- Manual Descent Cable
- Diamond Tread Steel Deck
- Greaseless Kingpin Joints
- Analyzer Port for Diagnostics
- Dynamic Braking
- Flashing Amber Beacon
- Self-Closing, Self-Latching Gate



ACCESSORIES & OPTIONS

- 220 Amp-Hour AGM Batteries
- MDI (Ground)
- Anti-Vandalism Package for Ground Controls and Platform Controls
- Ambient Noise Alarm
- AC Outlet To Platform incl. ELCB

19ft Scissor Lift

Dimensions

All dimensions are approximate.

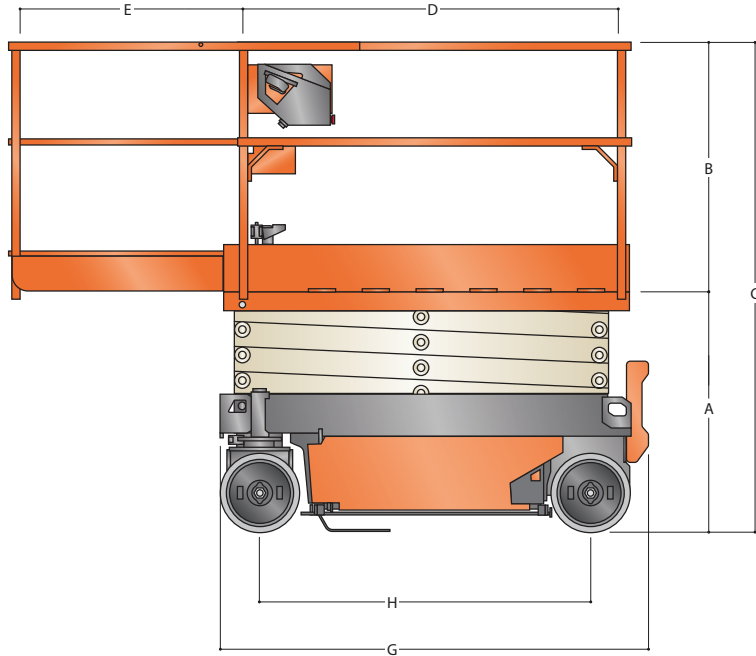
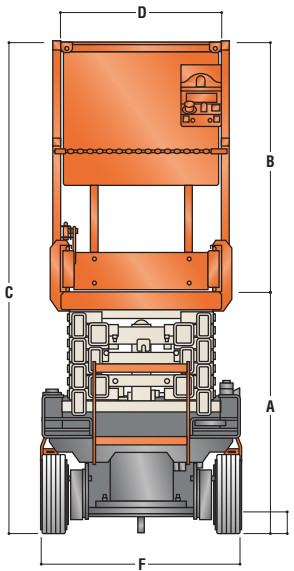

A. Platform Height-Lowered	0.98 m
B. Platform Railing Height	1.02 m
C. Overall Height	2.00 m
D. Platform Size	0.64 m x 1.59 m
E. Platform Extension	0.86 m

F. Overall Width	0.82 m
G. Overall Length	1.74 m
H. Wheelbase	1.34 m
I. Ground Clearance	0.07 m